

Manual for **PMU** *Master* PMU machine rev.1



Manufacturer: InkMachines Sweden AB
Grusåsvägen 8
352 42 VÄXJÖ, Sweden



Document history

Date (YY-MM-DD)	Changes	Revision
2022-10-01	Released	1.0

This document has been produced by
InkMachines Sweden AB
Grusåsvägen 8
352 45 VÄXJÖ, Sweden

Table of Contents

Document history.....	2
Table of Contents	3
Introduction	4
Document information.....	4
Description	5
Parts of the PMU machine	5
Intended use.....	5
Approvals.....	6
Identification labels	6
Safety	7
Regulations.....	7
Product	7
Customer	7
Cleaning and hygiene	7
Delivery	9
Unpacking.....	9
Instruction.....	10
RCA connection	10
Status LED.....	10
Basic setup instructions.....	11
After each PMU session	14
Converting to regular cartridges (Neo version).....	15
Adjusting the give hardness	18
Converting to Neo-cartridges.....	19
Adjusting the stroke length.....	22
Change the drive magnet.....	23
Service and maintenance	24
Lubrication.....	24
Trouble shooting	25
Waste	26
Technical specification	27
PMU Master	27
Warranty.....	28
Part-list.....	29
DoC.....	31

App.

Declaration of Conformity for FCC and CE

Warranty

Certificate Electromagnetic compatibility

Introduction

Document information

This Manual does not teach any form of PMU techniques and only covers the aspects and handling the PMU Master machine itself.

Information in this document is subject to change without notice. InkMachines assumes no responsibility for any errors that may appear in this document.

Stylistic conventions

In this manual all references texts are shown in the text font *italic*.

Cautions and Notes are shown as below.

Text

Description

PMU Master is a PMU machine intended for micropigmentation of humans for the use by professional PMU artists. The machine is intended to use together with Neo or regular cartridge PMU needles depending on the version purchased. PMU Master can be connected to TPS-500 X2 or other power supply units intended for the purpose, by RCA.

PMU Master is provided with active vibration damping which means when the PMU needle is mounted the vibrations from the machine are low which makes it very ergonomic to work with. When used together with Neo-Cartridge needles. The needle movement is driven magnetically. This together with the needle design with a one-piece polymer body minimizes the risk of cross-contamination between the needle and the machine.

Parts of the PMU machine

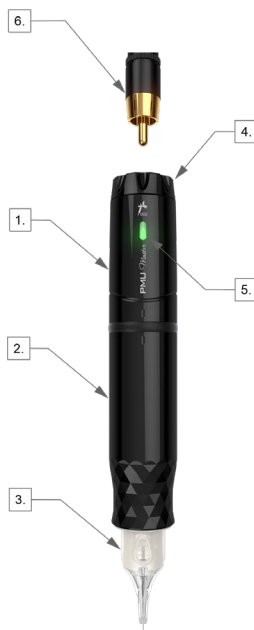

PMU *Master*

1. Machine body
2. Grip
3. Needle (Neo-Cartridge)
4. Needle adjustment knob
5. Status Led
6. RCA cable (not included)

Intended use

The PMU Master is designed and developed solely for micropigmentation of humans for the use by professional PMU artists with good knowledge of hygiene, how to prevent spreading infections and local regulations regarding this.

Approvals

This product complies with the Europe requirements for CE-marking towards the Machine Directive, 2006/42/EC.

See Declaration of conformity in the end of the manual.

Identification labels

The product is labelled according to below;



Safety

Regulations

Always follow local regulations concerning the PMU operation. It is the operator's responsibility to follow regulations and to provide a reliable environment for their customers.

The manufacturer does not have responsibility for any kind of material or personal damage or infection caused by the operator. Negligence or misuse of the machine or the components attached to the machine is the operator's responsibility.

The manufacturer does not have responsibility for contamination or infection.

Product

To keep your product in good shape handle it with care!

The product should not under any circumstances come in direct contact with fluids. If fluids will get in contact with the electronics, it can damage the product.

Keep the product away from warm places.

Customer

InkMachines only provide products for professional PMU artists and the product may only be used by professionals with knowledge about diseases and how to maintain a clean working environment and a sterile equipment.

Always use:

- sterile grips and needles
- rubber/disposable gloves
- plastic bags and wraps for PMU equipment; around the power supply, the machine and the power cord

Always keep your equipment clean! See below for further instruction.

Cleaning and hygiene

Cleaning

Caution! Never spray or pour fluids directly on any of the units, it can cause short circuit and will void the warranty.



It is important for the PMU operation to keep a clean and hygienic environment to avoid infection.

Do NOT use strong alkaline (high pH) or acid (low pH) cleaning agents. Only use pH neutral cleaning agents and alcohol disinfectants. Use a dampened piece of paper or cloth to gently wipe off surfaces of the units.

Hygiene

- Do not touch sterilized grip or sterile needles with bare hands. Use disposable gloves!

- Needles would be hold as shown in the picture. Do not touch the part of the needle to be inserted into the PMU machine.

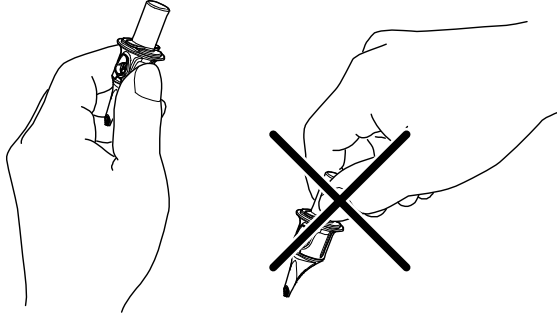

- Clean the work surface thoroughly and cover the surface with plastic film before the PMU session.
- Wrap the equipment with plastic film and arrange it as described in chapter *Getting started* on page 10.
- Follow local laws and regulations concerning the PMU operation.

Delivery

Delivery

When your package is delivered, please check that:

- there are no transport damages
- everything is delivered accordingly.

Unpacking



Note! Before unpacking make sure the area is cleaned!

Standard parts delivered with the Neo-cartridge version:

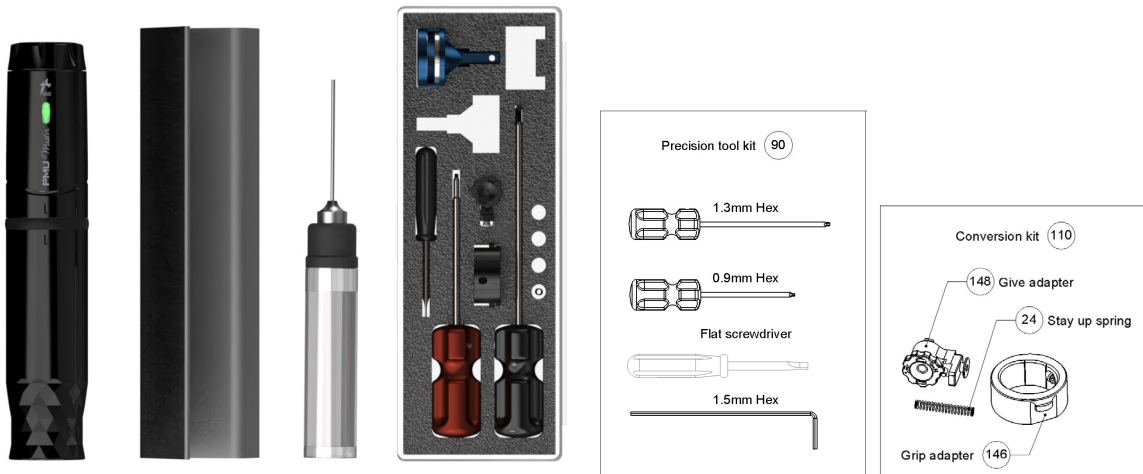

- 1pc PMU Master machine
- 1pc Stand for needles (For Neo-Cartridges)
- 1pc oiler
- 1pc Magnet Blue (in the kit). Black standard in the machine
- 1pc Precision tool kit No-90
- 1pc Conversion kit No.110

For the Regular cartridge version, the following items are excluded:

- No. 146 - Grip adapter
- No. 24 - Stay up spring
- No. 217 - Counter weight assy
- No. 220 - Drive magnet STD (Black)
- No. 221 - Drive magnet (Blue)
- No. 150 - Neo needle stand

Instruction

RCA connection

The PMU master works with regular power supplies between 6-12V with standard RCA cables.





The RCA contact is not rotating when the needle depth is adjusted. It prevents the RCA cable from twisting during operation.

Status LED

The PMU master is equipped with a status LED that indicates if something is wrong.

Status Light

When the light is on the current is reaching the motor

		
Green	Orange	Red
The load is within limits	The load is in upper limit and ok for shorter periods	The load is above limits and machine should be checked

Basic setup instructions



1. Make sure the workspace is thoroughly cleaned and disinfected.
2. Use disposable gloves when preparing the PMU machine and work surface.
3. Cover the work surface with plastic film.
4. Hold the PMU machine and turn grip 30° counterclockwise to remove the grip from the PMU machine.



5. Sterilize the grip.
If disposable grips are used; discard the grip and use a new one.
6. Fit the grip as shown in the picture.
7. Turn the grip 30° clockwise.



Note! The mark on the grip and the mark on the tattoo machine should be aligned when the grip is correctly fitted to the PMU machine.



8. Wrap the PMU machine and the cable with plastic tube or film.
Seal with tape on the sterile grip.

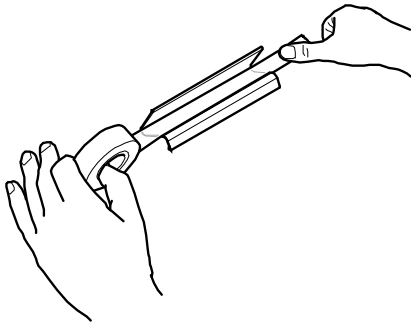

9. Tape the needle stand to the table.

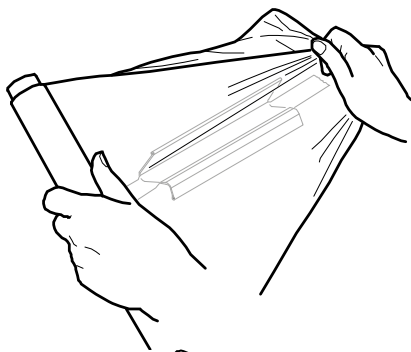

10. Wrap the needle stand with plastic film.

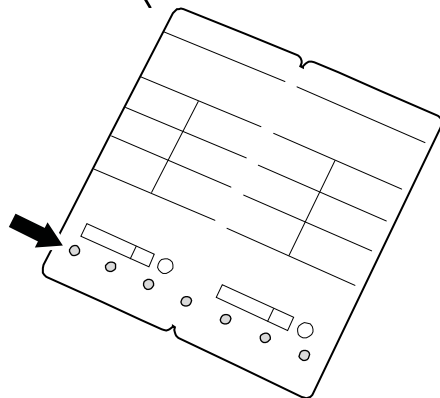

11. Prepare needles. Check that the dots at the bottom of the needle package are NOT Blue. If the dots are blue the needle package is not sterile and should not be used.

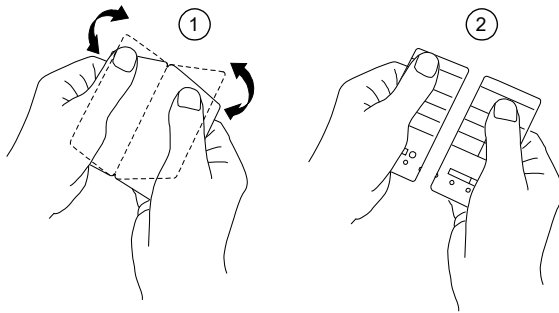

12. Remove a needle package from the other and open it.

Note! When a needle package is to be parted from the other do not tear them apart. Fold back and forth repeatedly until the package releases from the rest. Otherwise there is a risk of damaging the adjacent package. The needle in the package is then no longer sterile and should not be used.

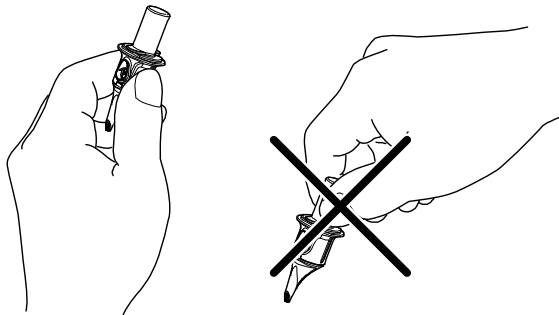

Note! When handling the needle, do not touch the part of the needle that is to be inserted into the PMU machine

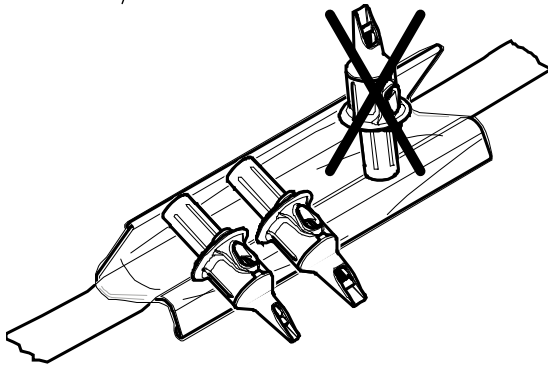

13. Place the number of needles needed during the work in the needle stand. The needles should be placed as shown. If you need more needles use one more stand.



14. Insert a needle in the PMU machine.



15. Turn the needle 90° to lock it. About 30° if it's a regular cartridge.

16. Set the voltage on the powersupply

Appropriate start value: 7.5 – 9V.

17. Adjust the needle's protrusion (depth) by turning the adjustment knob. One revolution equals 2mm.

18. The PMU machine is now ready for use.

After each PMU session

After each PMU session the used PMU needles should be destructed. Consumables and packaging such as plastic film, plastic bags, needle packaging etc. should be disposed.

Remove the grip from the PMU machine and sterilize it. Wipe down the machine with alcohol and stir the magnet in a cup of alcohol (Neo version).

Converting to regular cartridges (Neo version)

InkMachines recommends that Neo-cartridges are used for optimal performance and safety with the PMU Master machine. With regular cartridges some advantages will be lost. For example, the Neorail cannot be used, the safety and healing advantages will also be lost.

Caution! InkMachines does not have responsibility for any fluids or pigments entering the machine after using other cartridges than original Neo-cartridges. InkMachines does not have responsibility for contamination or infection of any kind. To avoid cross-contamination between the needle and the PMU machine with regular cartridges, always use cartridges with membrane.
Never use cartridges without a sealing membrane.

You need one *Conversion kit No. 110* for regular cartridges and one *Precision tool kit No. 90*.

Conversion kit No. 110

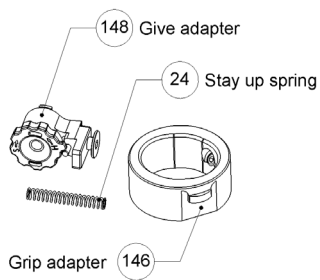

Stay up spring No. 24
Give adapter No. 148
Grip adapter No. 146

Precision tool kit No. 90

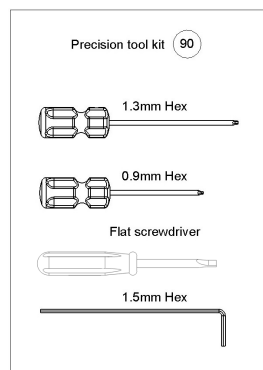



1. Remove the grip from the PMU machine and turn the adjustment knob counter clockwise so the inner tube (motor) is as far out as possible, it will make it easier to reach all components.



2. Remove the Drive magnet by loosen the Magnet holder screw on the side of the plastic slide with the 1.3 Hex key from the *Precision tool kit No.90*.



3. Leave the Magnet holder screw in the Magnet holder to prevent the screw from disappearing. Keep the magnet in a plastic bag to keep free from dirt.



4. Use the 1.3 Hex key to remove the Counterweight screw on the "1" side of the machine, remove the Counterweight.



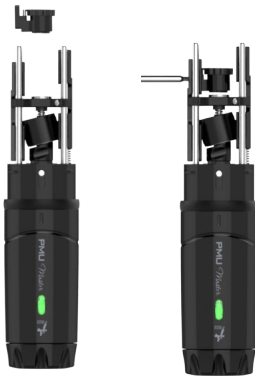

5. Mount the Give adapter No. 148 (included in *Conversion kit No. 110*) on the side of un-marked side, make sure the screw goes smooth into the Give adapter, if not back the screw out, align and try again so that the thread is not damaged. Tighten gently.

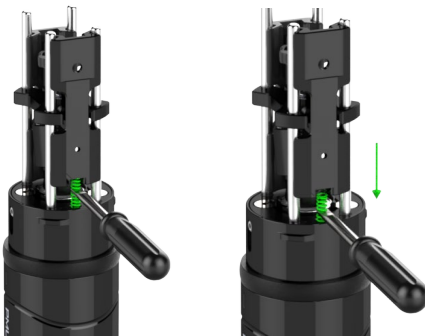

6. Remove the Stay up spring No. 24 on the side "1", by pressing down the spring with the small flat screwdriver. Put one corner of the screwdriver between the fourth and fifth coil and press the spring down as straight as possible until it comes clear and can be taken out. Keep your thumb over it so it doesn't spring away.

Note! Be careful when pressing down the spring not to bend it.

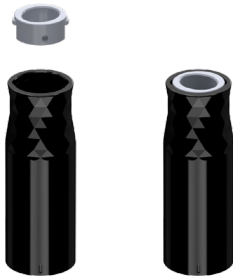

7. If you don't have a one-piece grip for regular cartridges and want to use a Neo grip with the adapter. Place the Grip adapter No. 146 (included in the *Conversion kit No. 110*) in the grip and turn the grip adapter 90° clockwise. The Grip adapter is only for metal grips and not for disposable grips.



8. Tighten the screw with the 0.9 Hex key (red) from the *Precision tool kit No. 90*. Make sure the key engages in the screw properly before tightening so the screw is not damaged. Tighten medium hard and make sure you don't bend to the side which can damage the key or screw.

Adjusting the give hardness



9. Adjust hardness of the give.
If the screw driver is used the grip does not have to be removed and can be done during session. The hardness can be controlled (felt) by pushing on the Give adapter.

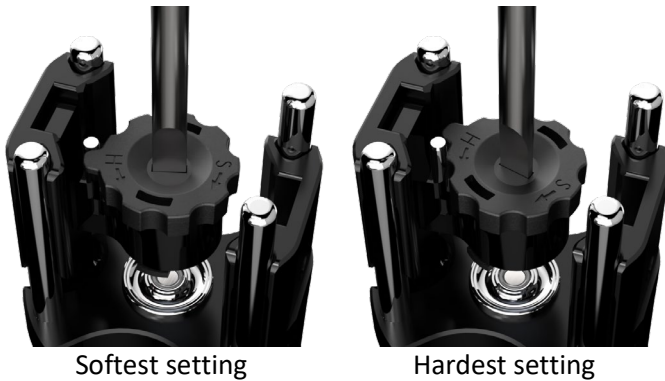

10. Fit the grip and then turn the grip 30° clockwise.

The PMU machine is now ready to be used with regular membrane cartridges.

Converting to Neo-cartridges

If you have the regular cartridge version you need the No. 270 - Regular to Neo Kit.

1. Remove the grip from the machine.



2. Remove the Give adapter No.148 from the plastic slide by using the 1.3 Hex key from the *Precision tool kit No.90*.



3. Mount the Counterweight on the Slide on the side marked "1". When correct mounted, the counterweight and the spring should both be located on the "1" side of the machine.



Note! Do not tighten the screw to tight.

4. Mount the Magnet holder with magnet on the Slide on the un-marked machine side.



5. Mount the Stay up spring No. 24 placed on the machine side "1", by pressing down the spring with the small flat screwdriver. Put one corner of the screwdriver between the fourth and fifth coil and press the spring down as straight as possible until it comes clear and can be inserted.

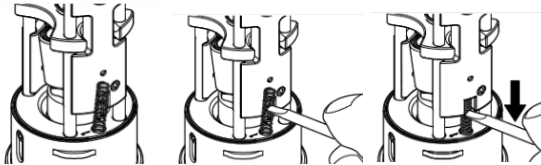

6. Loosen the grip adapter screw with the 0.9mm hex key from the *Precision tool kit No. 90*.



7. Turn the grip adapter 90° counterclockwise and remove it from the grip.

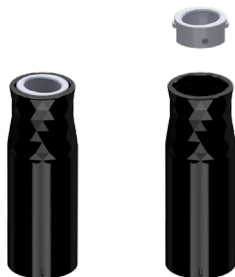









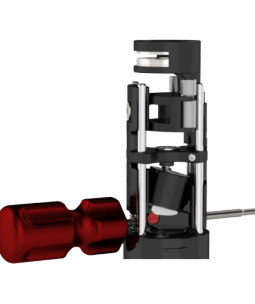

8. Fit the grip and then turn the grip 30° clockwise.

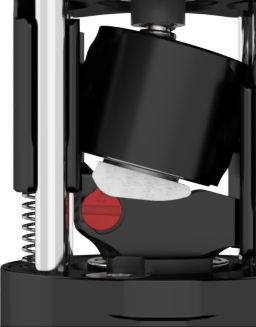
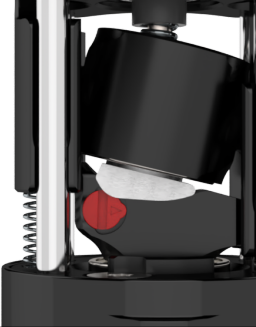
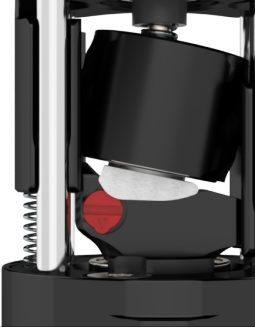
The PMU machine is now ready to be used with Neo-cartridges.

Adjusting the stroke length

<p>1. To change stroke length you need the red 0.9mm hex key and the 2mm wide screw driver from the tool kit. No.90. Also included with the purchase of the machine.</p> 	<p>2. Use the screw driver to block the swash and keep it from rotating for the next step.</p> 	<p>3. Use the red key to loosen the locking screw. Make sure the key is seated all the way in the screw before loosening it. A half turn is enough.</p> 	<p>4. Now use the red key to block the swash on the other side to keep it from rotating for the next step.</p> 
<p>5. Insert the screw driver in the stroke adjuster to choose stroke length. (The red plastic part on the swash)</p> 	<p>6. Pointing up = 4mm stroke</p> 	<p>7. Pointing to the right = 3.5mm stroke.</p> 	<p>8. Pointing down = 3mm stroke.</p> 
<p>9. Repeat step 2.</p> 	<p>10. Use the red key to tighten the locking screw. Dont tighten this screw very hard.</p> 	<p>11. The stroke is now set and the machine is ready for use.</p> 	

Change the drive magnet

If a softer punch is required, the standard Drive magnet (Black) can be replaced with a softer Drive magnet (Blue). The Blue magnet is included in the tool kit in the box of the Neo version.



1. Remove the grip, Hold the PMU machine and turn the grip 30° counterclockwise to remove the grip from the PMU machine.



2. Remove the drive magnet by loosen the screw on the side of the slider with the Black 1.3mm key from the tool kit No. 90.



3. Remove the magnet assembly.



4. Place the Blue drive magnet in the slider. Check that the magnet holder is parallel to the slider before tightening the screw. Mis-alignment can damage the thread. Fasten the magnet holder with the screw.



5. Fit the grip and then turn the grip 30° clockwise.

Service and maintenance

For service and repair visit www.inkmachines.com/service

Caution! Changes or modifications not approved by the manufacturer could void the warranty.

Lubrication

The PMU machine should be lubricated every 100-150 hours for optimal performance and service life. Use the oil included in the delivery of the machine.

- Remove the grip (see point 4 at page 11).
- Lubricate the indicated spots on the PMU machine with one drop on each spot, in the 2 holes in the sliders and on the 8 contact points between the sliders and pins. Do not oil the bearings and don't over oil as it can enter the motor. This can compromise the electric properties.



- Run the PMU machine for a while to distribute the oil.
- Wipe off redundant oil with a soft cloth.
- Refit the grip on the PMU machine (see point 6-7 on page 11).

Trouble shooting

- **If the machine does not start or fluctuates:**
 - Make sure that the Power supply / RCA cable is functional and that the pin on the male RCA contact is not too small. It should have a tight fit in the female RCA contact of the machine.
 - If the problem remains, contact InkMachines (www.inkmachines.com)

Waste

The manufacturing company is responsible for disposal of the Product. To avoid environment pollution and human injury follow local regulation concerning waste of electronic products. This product contains rechargeable and not rechargeable batteries. In the interest of protecting the environment and human health, please send the rechargeable batteries back to the manufacturer for exchange and follow local regulations concerning waste of batteries.



This symbol indicates that the product and its electronic accessories are not to be disposed with other house hold waste.

Technical specification

PMU Master

Dimension, D x L	Ø22 x 105 mm
Weight	95 grams with 19mm PMU grip
Power connections	RCA
Motor	8+ Watt
Input voltage	0 – 12 V DC (max. 12 V DC)
Rotational speed interval	0 – 8000 rpm
Stitches/second	0 - 130
Stroke length	3-4 mm
Needle adjustment	4 mm
Needle type	Neo-Cartridges / Regular Cartridges
Max. needle size	27 Magnum

Warranty

This product includes a 12 months warranty from the date of purchase. The warranty applies to factory faults and not to wear of any components caused by normal or abnormal use.

If this product becomes defective during the Warranty period, InkMachines shall have the option, in its sole discretion, to either repair the product or replace the product. Shipping costs to repair destination is not covered.

The warranty is void if:

1. The machine has been opened in an inappropriate way.
2. The machine has been autoclaved or cleaned in an ultrasonic cleaner.
3. Components have been damaged by misuse or carelessness.
4. Components have been manipulated in a harmful way.
5. Alkaline or acid cleaning agents with strong bases (high or low pH) have been used on the products.
6. More than 12 Volts have been applied to the machine.

InkMachines entire aggregate liability for losses and damages for any cause related to or arising out of the purchase and/or use of the product will in no event exceed the purchase price paid for the product. In no event will InkMachines be liable: (a) any indirect, special, incidental, consequential or punitive loss or damage, or other economic loss of any kind, in any case, even if advised of, or if InkMachines could reasonably foresee, the possibility thereof. The limitations, exclusions and disclaimers in this agreement shall apply irrespective of the nature of the cause of action, demand, or proceeding including but not limited to, breach of contract, negligence, tort, strict liability or any legal or equitable theory.

Part-list

Part list PMU master tattoo machine

<p>Precision tool kit (90)</p> <p>1.3mm Hex</p> <p>0.9mm Hex</p> <p>Flat screwdriver</p> <p>1.5mm Hex</p>	<p>PMU Screw kit (462)</p> <p>M2x2 (3x)</p> <p>M2x3 (1x)</p> <p>M2x4 (1x)</p> <p>M2x8 (2x)</p> <p>M2x3 (2x)</p>	<p>Regular to Neo Kit (270)</p> <p>220</p> <p>24</p> <p>221</p> <p>217</p>
<p>PMU Motor assy (435)</p>	<p>Oil (56)</p>	<p>Neo needle stand (150)</p>
<p>Conversion kit (110)</p> <p>24 Stay up spring</p> <p>148 Give adapter</p> <p>Grip adapter 146</p>		<p>X2 X-ring assy (260)</p>

Part-list

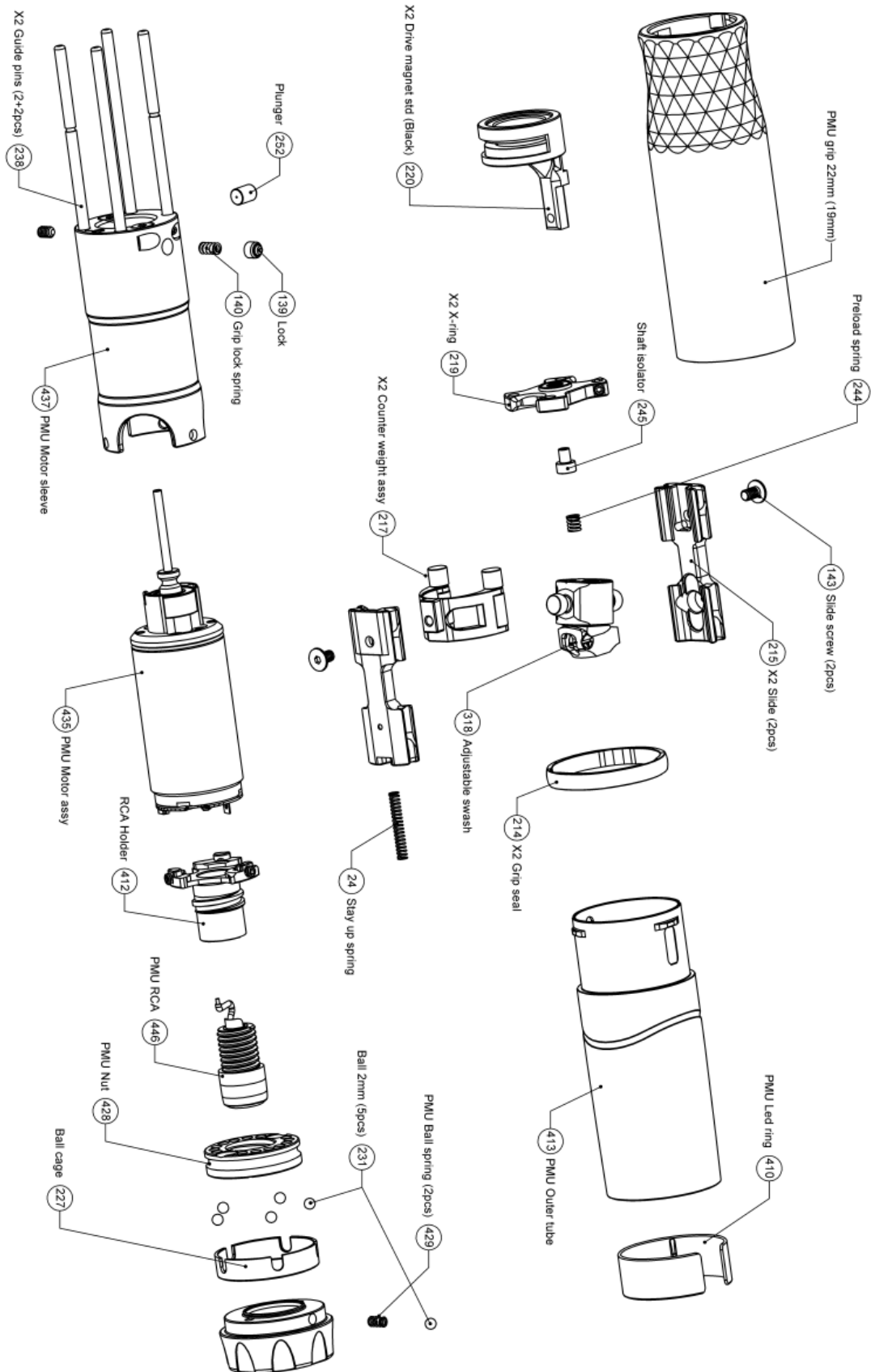

DoC



Declaration of Conformity

Manufacturer

InkMachines Sweden AB
Grusåsvägen 8
352 45 Växjö
Sweden

Equipment

PMU machine PMU Master
Year of manufacturer 2021

We InkMachines Sweden AB hereby declare that the PMU Master PMU machine specified above conforms with the following directives:

Machine Directive 2006/42/EC

Växjö 2021-12-20



.....

Christian Johansson CEO